



TC-940Ri

DIGITAL CONTROLLER FOR
REFRIGERATION AND DEFROST
WITH ALARM OUTPUT

Ver.04



TC940V04-02T-10789

1. DESCRIPTION

The **TC-940Ri** is a digital controller of temperature that manages defrost cycles and evaporator fans. This instrument also has an output for alarm.

An innovative feature of TC-940Ri is the possibility that the controller offers initiating a defrost cycle evaporator temperature, detecting the moment that the system needs to do defrost. Thus, it is possible to save energy and increase the efficiency of the system.

Product in agreement with CE (European Community) and UL Inc. (USA and Canada).

2. APPLICATION

- Counters
- Refrigerated balcony

3. TECHNICAL SPECIFICATIONS

- Power supply: TC-940Ri - 115/230 Vac \pm 10% (50/60 Hz)
TC-940RiL - 12/24 Vac/dc

- Control temperature: -50 to 75°C / -58 to 167°F
- Resolution: 0.1°C from -10 to 75°C and 1°C outside this range / 1°F
- Operating temperature: 0 to 50°C / 32 to 122°F
- Operating humidity: 10 to 90% RH (without condensation)
- Dimensions: 71 x 28 x 71mm
- Load current (outputs):

REFR: 5(3)A/250Vac 1/8HP (compressor, solenoid valve or contactor)

FANS: 5(3)A/250Vac 1/8HP (evaporator fans)

DEFROST: 5(3)A/250Vac (defrost - resistance or hot gas)

ALARM: 3A/250Vac resistive load (external alarm)

CLASSIFICATION ACCORDING TO IEC60730-2-9 STANDARD:

- Temperature limit of the installation surface: 50°C / 122°F
- Type of construction: Built-in electronic controller
- Automatic action: Type 1
- Control of pollution: Level 2
- Impulse voltage: 1.5kV
- Temperature for the test of sphere pressure: 75°C and 125°C / 167°F and 257°F
- Insulation: Class II

4. CONFIGURATIONS

4.1 - Control temperature adjust (SETPOINT)

Press **SET** for 2 seconds until appears **SEt**, and release it after that. The adjusted operation temperature will appear. Use the keys **▲** and **▼** to change the value and then press **SET** to record it.

4.2 - Parameters table

Fun	Description	CELSIUS				FAHRENHEIT			
		Min	Max	Unit	Standard	Min	Max	Unit	Standard
F01	Access code: 123 (one hundred and twenty-three)	-99	999	-	-	-99	999	-	-
F02	Control differential (hysteresis)	0.1	20.0	°C	1.5	1	36	°F	3
F03	Offset indication for ambient sensor	-20	20.0	°C	0.0	-36	36	°F	0
F04	Minimum setpoint allowed to the end user	-50	75.0	°C	-50	-58	167	°F	-58
F05	Maximum setpoint allowed to the end user	-50	75.0	°C	75.0	-58	167	°F	167
F06	Defrost type (0 = resistance; 1 = hot gas)	0	1	-	0	0	1	-	0
F07	Initial defrost condition (0 = time; 1 = temperature)	0	1	-	0	0	1	-	0
F08	Period between defrost (if F07 = 0)	1	999	min.	240	1	999	min.	240
F09	Maximum time in refrigeration (for security, if F07 = 1)	1	240	hour	24	1	240	hour	24
F10	Temperature in the evaporator for defrost start (if F07 = 1)	-50	75.0	°C	-5.0	-58	167	°F	23
F11	Time of pre-defrost (if F07 = 1)	0	90	min.	10	0	90	min.	10
F12	Defrost when the instrument is powered on (0 - no; 1 - yes)	0	1	-	0	0	1	-	0
F13	Evaporator temperature (S2) for end defrost	-50	75.0	°C	40.0	-58	167	°F	104
F14	Maximum defrost duration (for security)	0	90	min.	45	0	90	min.	45
F15	Fan turned on during defrost (0 - no; 1 - yes)	0	1	-	0	0	1	-	0
F16	Delay to do the first defrost (if F07 = 0)	0	999	min.	0	0	999	-	0
F17	Locked temperature indication (S1) during defrost (0 - no; 1 - yes)	0	1	-	0	0	1	-	0
F18	Draining time (dripping of defrost water)	0	30	min.	10	0	30	min.	10
F19	Evaporator temperature (S2) for fan return after draining	-50	75.0	°C	0.0	-58	167	°F	32
F20	Maximum time for fan return after draining (fan-delay)	0	3	min.	1	0	30	min.	1
F21	Fan on with compressor off (refrigeration)	0	1	-	1	0	1	-	1
F22	(0 - no; 1 - yes) Fan stop for high temperature in evaporator	-50	75.0	°C	75.0	-58	167	°F	167
F23	Differential for fan return (after stopping for high temperature in evaporator)	0.1	20.0	°C	2.0	1	36	°F	4
F24	Low temperature alarm (S1)	-50	75.0	°C	-50	-58	167	°F	-58
F25	Alarm differential of low temperature	0.1	20.0	°C	1.0	1	36	°F	2
F26	High temperature alarm (S1)	-50	75.0	°C	75.0	-58	167	°F	167
F27	Alarm differential of high temperature	0.1	20.0	°C	1.0	1	36	°F	2
F28	Inhibition time of alarm when the instrument is powered on	0	999	min.	0	0	999	min.	0
F29	Inhibition time of alarm after draining	0	999	min.	0	0	999	min.	0
F30	Delay when the instrument is powered on	0	999	min.	0	0	999	min.	0
F31	Minimum time of compressor turned on	0	999	sec.	0	0	999	sec.	0
F32	Minimum time of compressor turned off	0	999	sec.	0	0	999	sec.	0
F33	Compressor status with detached ambient sensor (0 = off; 1 = on)	0	1	-	1	0	1	-	1

4.3 - Parameters description

F01 - Access code (123)

It is necessary to change the configuration parameters. To visualize the adjusted parameters, it is not necessary to insert this access code.

F02 - Control differential (hysteresis)

It is the difference of temperature (hysteresis) between ON and OFF the refrigeration.

Example: You need to control temperature in 4.0°C with differential of 1.0°C.

So, the refrigeration is turned off in 4.0°C and will be turned on in 5.0°C (4.0 + 1.0).

F03 - Offset indication for ambient sensor

It allows to compensate eventual shunting lines on reading of ambient temperature (S1), proceeding of sensor exchange or cable length alteration.

F04 - Minimum setpoint allowed to the end user

F05 - Maximum setpoint allowed to the end user

It is to prevent that incorrect high or low temperatures be regulated.

F06 - Defrost type

"0" = Electrical defrost (resistances), where is kept on only the defrost output.

"1" = Hot gas defrost, where defrost and compressor outputs are kept on.

F07 - Initial defrost condition

It defines if the defrost start will be for temperature or time. Is this function has the value "1", when the evaporator temperature reaches the configured value in "F10" the instrument starts to count the pre-defrost time and, after, will do the defrost.

F08 - Period between defrosts (if F07 = 0)

It determines the time between two consecutive defrost cycles, and starts to be counted from the last defrost. Attention, the defrost only will start if the temperature in S2 (evaporator sensor) is lower than F13.

F09 - Maximum time in refrigeration (for security, if F07 = 1)

It acts as security time if (F07 = 1) and evaporator temperature will not reach the configured value in "F10". This function determines the maximum time that controller will stay without defrost.

F10 - Temperature in the evaporator for defrost start (if F07 = 1)

When evaporator temperature reaches the configured value in this function the controller will start to count the pre-defrost period (F11).

F11 - Time of pre-defrost (se F07=1)

At the moment that the temperature in evaporator decreases and reaches the configured value in "F10", start to be counted the pre-defrost time. During the pre-defrost stage, if the temperature is kept low the defrost starts, else if the temperature increase at least 1°C in relation to configured value, the system returns to refrigeration stage.

F12 - Defrost when the instrument is powered on

It possibilities the defrost at the moment that the controller is turned on, for example, in return of electrical energy (in case of energy lacks).

F13 - Evaporator temperature (S2) for end defrost

If evaporator temperature (sensor S2) reaches the adjusted value, the end defrost will happen for temperature. With this, the defrost process is optimized.

F14 - Maximum defrost duration

This function serves to adjust the maximum value of time to defrost. If in this period the evaporator temperature will not reach the configured value in F13 a point will be blinking on inferior down right side of display indicating that the end defrost occurred for time and not for temperature.

This can happen when the adjusted temperature is very high, the limit time will be not enough, the S2 sensor is detached or not in contact with the evaporator.

F15 - Fan turned on during defrost

It possibilities the fan functioning during defrost.

F16 - Delay to do first defrost (if F07=0)

This function defines an extra time that the instrument will keep in refrigeration before do the first defrost, to prevent that lot of counters enter in defrost at the same time. This time only appears before the first defrost, when F07 = 0 (initial defrost for time).

F17 - Locked temperature indication (S1) during defrost

This function prevents that ambient temperature elevation be visualized. During defrost the last measured temperature in refrigeration cycle will be locked on display. The indication will be released when this temperature will be reached again or 15 minutes after the begin of next refrigeration cycle.

F18 - Draining time (dripping of defrost water)

Necessary time for dripping, it means, to drain the last water drops of the evaporator. All the outputs keep turned off. If you do not need this stage, adjust this time for "zero".

F19 - Evaporator temperature (S2) for fan return after draining (fan-delay)

After the draining, the fan-delay cycle starts. The refrigeration (REFR.) output is turned on, because the evaporator temperature is high, but the fan only is turned on after evaporator temperature decreases the adjusted value. This process is necessary to remove the heat that exists in the evaporator because the defrost, preventing to pass it to the ambient.

F20 - Maximum time for fan return after draining (fan-delay)
For security, if the evaporator temperature does not reach the adjusted value in F19 or the S2 sensor is detached, the fan-delay will happen after passed the adjusted time in this function.

F21 - Fan on with compressor off (in refrigeration)
During refrigeration, the fan can be depend of the compressor status.
"0" = The fan keeps turned on while compressor is turned on (this alternative, in some cases, possibilities a great economy of electrical energy).
"1" = The fan keeps turned on during all refrigeration cycle.

F22 - Fan stop for high temperature in evaporator
This function cycles the evaporator fan until that ambient temperature approaches of the temperature desired in the refrigerating installation project. This preventing high temperature and suction pressures that can damage the compressor. If the temperature in evaporator pass the adjusted value, the fan is turned off, turning on again with a configurable hysteresis in F23.

F23 - Differential for fan-delay (after stopping for high temperature in evaporator)
It allows to determine the difference of temperature to fan-delay had to a stop for temperature above desired in evaporator.

F24 - Low temperature alarm (S1)
If the ambient temperature (sensor S1) decreases above this point during refrigeration, this will be signaled through the message **ALo** on display and the output (NO) of alarm will be turned on.

F25 - Alarm differential of low ambient temperature
It is the difference of temperature to turn off the alarm output for low ambient temperature.

F26 - High temperature alarm (S1)
If the ambient temperature (sensor) reaches this point during the refrigeration, this will be signaled through the message **AHh** on display and the output (NO) of alarm will be turn on.

F27 - Alarm differential of high temperature
It is the temperature to turn off the alarm output for high ambient temperature.

F28 - Inhibition time of alarm when the instrument is powered on
During this time the alarm is kept turned off waiting that the system starts to working.

F29 - Inhibition time of alarm after draining
This function serves to inhibit the alarm during a period after draining, because it is normal an elevation of the temperature proceeding of the defrost.

F30 - Delay when the instrument is powered on
When the instrument is turned on, it can keep a time with its control disabled, delaying the process initial. During this time it functions only as temperature indicator. It serves to prevent demand peaks of electrical energy, in case of lack or return of the same, when a lot of equipments are connected in the same line. For this, adjust different times for each equipment. This delay can be of compressor or defrost (when exists defrost on start).

F31 - Minimum time of compressor turned on
It is the time that the compressor will keep turned on, it means, the time period between the last started and the next stopped.

F32 - Minimum time of compressor turned off
It is the minimum time that the compressor will keep turned off, it means, the time period between the last stopped and the next started. It serves to alleviate the pressure and to increase the useful life of the compressor.

F33 - Compressor status with detached ambient sensor (S1)
If the ambient sensor (S1) is detached or out specified range, the compressor assumes the configured status in this function.
Example: For counters that storage fruits it is better that the compressor keeps turned off, but in counters that storage meals it is better that the compressor keeps turned on.

4.3.1 - Unit selection (°C/°F)

To determine the unit that the instrument will work, access the function "F01" with the access cod 231 and confirm with the key **SET**. Press the key **▲**. **Un** will appear. Press **SET** than use **▼** or **▲** to choose between **°C** or **°F** and confirm with **SET**. After select the unit **FRL** will appear and the instrument returns to the function "F01". Every time that the unit is changed, the parameters must be configured again, because they assume the standard values (item 2.4).

5. OPERATION

5.1 - Parameters visualization

- Press at the same time the keys **▼** and **▲** for 2 seconds until appear **FUn**, releasing them after that. Soon, appears **F01**.
- Use the keys **▼** and **▲** to access the desired function.
- After select the function, press **SET** (short touch) to visualize the configured value.
- Press again **SET** (short touch) to return the functions menu.
- To reset the menu and return to normal operation (temperature indication), press **SET** until appear **--**.

5.2 - Parameters alteration

- Access the function F01 pressing at the same time **▼** and **▲** for 2 seconds until appear **FUn**, releasing then after that. Soon will appear **F01**, and then press **SET** (short touch).
- Use **▼** and **▲** to enter the access code (123), and then press **SET**.
- Select the desired function and visualize the configured value, like explained the itens "5.1-b" and "5.1-c".
- Use **▼** and **▲** to change the value and then press **SET** to record the configured value and return to the functions menu.
- To reset the menu and return to normal operation (temperature indication), press **SET** until appear **--**.

5.3 - Process stage, elapsed time and evaporator temperature (S2)

Press **▼**. The stage of the process will appear, the elapsed time (in minutes) and evaporator temperature (S2).

In case of detached sensor or temperature out specified range will appear **Err2**.

Process stages: **dEL** Initial delay (delay to start the control)

- FAn** Fan-delay (delay to fan return)
- rEF** Refrigeration
- PrE** Pre-defrost (only if F07 = 1)
- dEF** Defrost
- drE** Draining



5.4 - Initial defrost condition

The function "F07" determines if the start of the defrost will be for time or temperature.

F07 = 0 The start of defrost will happen after elapsed the configured time in F08.

F07 = 1 When the temperature in the evaporator reaches the configured value in F10, the count of pre-defrost period will start (F11). After elapsed this time, if the temperature keeps low the defrost will start. If the temperature increases, the controller returns to refrigeration stage.

5.5 - How to determine the end defrost for temperature

- Adjust the follow functions with maximum values:
 - Interval between defrosts (F08 = 999 min)
 - Evaporator temperature for end defrost (F13 = 75 °C)
 - Defrost maximum duration (F14 = 90 min)
- Wait until an ice layer to be created on the evaporator.
- Do a manual defrost, pressing **▲** or 4 seconds, until appear **dEF Un**.
- Observe the melting process.
- Wait until melt all defrost on evaporator to consider the defrost finalized.
- Check the temperature in evaporator read by the sensor S2 at this moment, pressing **▼** and copy this value to the function F13 - Evaporator temperature (S2) for end defrost.
- As security, adjust again the function F14 - Maximum duration of defrost, that depends of the defrost type. **Example: Electrical defrost (resistance) = 45 minutes as maximum**
Defrost for hot gas = 20 minutes as maximum
- Now adjust the function F08 - Interval between defrosts as desired value.

5.6 - Manual defrost

To do a manual defrost, regardless of the programming, keep pressed **▲** for 4 seconds, until appears the indication **dEF Un**.

If the instrument is in defrost and you want to finish it, follow the above instructions, until appears the indication **dEF OFB**.

5.7 - Indicators and Alarms

The leds indicate the control outputs status:

REFR: Compressor or solenoid of liquid gas

FANS: Evaporator fans

DEFR: Defrost (resistances or hot gas)

ALRM: Alarm output

- Er1** Detached ambient sensor or temperature (S1) out the range
- Err2** Detached evaporator sensor or temperature (S2) out the range
- ALo** Low ambient temperature alarm
- AHh** High ambient temperature alarm
- ☐** Always that the defrost is finished by time and not for temperature a point located on right inferior side of display will be blinking until the next defrost, indicating that:
 - The interval between defrost is too long.
 - There are burned resistances
 - The hot gas is not circulating
 - There is an inoperative fan
 - The adjusted time for maximum duration of defrost is short.
- PPP** Invalid configuration parameters.
 - In this situation the outputs will be turned off.
 - Check which parameter have invalid information and correct it to return to normal operation.

5.8 - Registers of minimum and maximum temperatures

Press **▲**. Will appear **E-1** and minimum and maximum temperatures of black sensor (ambient). After appear **E-2** and minimum and maximum temperatures of gray sensor (evaporator).

Note: To reset the registers, keep pressed **▲** during visualization of minimum and maximum temperatures until appear **F5E**.

5.9 - Alarm inhibition

To inhibit the alarm press the key . The messages **ALP OFF** will appear. After the inhibition, the alarm output returns to be enabled when the instrument leaves the alarm status.

6. ELECTRICAL CONECTIONS

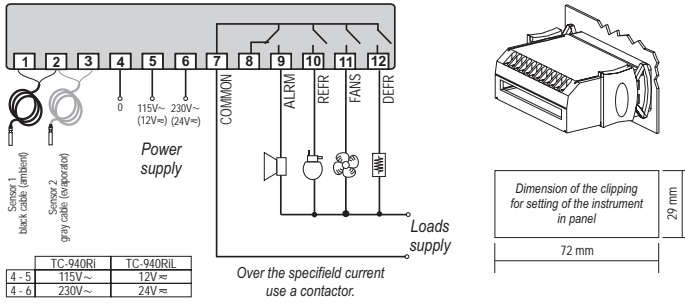

IMPORTANT

According to the chapters from the IEC60364 standard:

- 1: Install protectors against over voltage on power supply.
- 2: Sensor cables and computer signals can be together, however not at the same place where power supply and load wires pass for.
- 3: Install suppresor of transient in parallel to loads to increase the usefull life of the relays.

For more information contact our application eng. department through e-mail support@fullgauge.com or dial +55 51 3475.3308.

Contact suppresor connection diagram

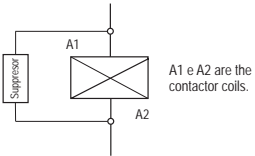

Diagram for suppresor installation for direct drive load inputs



Note: The sensor cable lenght can be increased by the user until 200 meters using 2 x 24 AWG cable.



PROTECTIVE VINYL:

This adhesive vinyl (included inside the packing) protects the instruments against water drippings, as in commercial refrigerators, for example. Do the application after finishing the electrical connections.

Remove the protective paper and apply the vinyl on the entire superior part of the device, folding the flaps as indicated by the arrows.

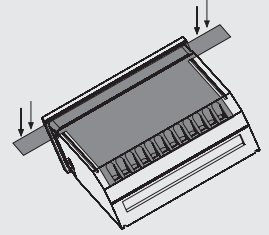

© Copyright 2006 • Full Gauge Controls® • All rights reserved.