



# PCT-100R<sub>i</sub>

## DIGITAL PRESSURE CONTROLLER

Ver.06



PCT100V06-01T-11722

### 1. DESCRIPTION

The **PCT-100R<sub>i</sub>** is a pressure controller that is easy to install and use. Designed for systems that require effective pressure control.

### 2. APPLICATION

Controls suction or discharge in cooling systems, air compressor control.

### 3. TECHNICAL SPECIFICATION

#### Controller

- Power supply: PCT-100R<sub>i</sub>: 115 or 230 Vac  $\pm$  10% (50/60 Hz)  
PCT-100R<sub>iL</sub>: 12 or 24 Vac/dc

- Control Pressure: 0 to 500 psi
- Resolution: 1 psi
- Maximum current: 16(8)A / 250Vac 1HP
- Dimensions: 71 x 28 x 71 mm
- Operating temperature: 0 to 50 °C
- Operating humidity: 10 to 90% RH (without condensation)

#### Transducer

- Power supply: 4.5 - 5.5Vdc
- Range: 0 to 500 psi
- Operating temperature: -40 to 100°C
- Output signal: 0.5 - 4.5Vdc @ 5Vdc (Ratiometric)
- Compatibility: Cooling fluids (including ammonia), compressed air, water

#### 3.1 - Control pressure adjust (SETPOINT)

- Press **SET** for two seconds and **SP** will appear.
- Wait two seconds and the adjusted control pressure will appear
- Use **SET** to modify the value.
- Wait 4 seconds to record and return to normal operation.

### 4. PARAMETERS TABLE

Function	Description	Min.	Max.	Unit	Standard
<b>OP</b>	Operating mode	0-depres	1-pres	-	1-pres
<b>dF</b>	Differential (hysteresis)	1	500	psi	20
<b>dL</b>	Minimum delay to connect the output	0	999	sec.	0
<b>OF</b>	Offset (local calibration)	-50	50	psi	0
<b>La</b>	Minimal adjustment allowed to the final user	0	500	psi	0
<b>Hi</b>	Maximum adjustment allowed to the final user	0	500	psi	500

- OP** This function allows configuration of the operating mode for the instrument (depressurization or pressurization);
- dF** Is the pressure difference (hysteresis) between ON and OFF for the "OUTPUT" control;
- dL** This is the minimum temperature output for the controller will remain off. This delay starts to be counted when the output is turned off.
- OF** Is the indication offset. Allows the compensation of any deviations in the pressure reading
- La** Range allowed to the final user to allow adjustments to the setpoint (minimum limit)
- Hi** Range allowed to the final user to allow adjustments to the setpoint (maximum limit)

### 5. PARAMETERS ALTERATION

The parameters are protected by an access code, (except the setpoint), which should be inserted in order to make the alterations.

To enter with the access code:

- Press **SET** for ten seconds and **CD** will appear.
- Wait 2 seconds and **000** will appear.
- Use the key **SET** to insert code 23 (twenty-three). This operation should be performed within four seconds, else the indication of the pressure returns automatically.

After inserting the access code:

- Press **SET** as many times as necessary, until accessing the desired parameter.
- Wait two seconds then the configured value will appear.
- Use the **SET** key to modify the value.
- Wait four seconds for the new value to be recorded, and the instrument returns to normal operations (pressure indication).
- To exit the parameters, wait the controller to show **CD** on the display.

NOTE: After inserting the access code, take special care to not leave the key **SET** idle (without being pressed) for more than fifteen seconds between the alteration of one parameter and another.

If it appears rapidly **CD** and the access to the adjustments is blocked automatically, sking for the code to be entered once again.

### 6. SIGNALLING

If the sensor is disconnected or the pressure is outside of the specified range, **Err** will appear on the display.

### OUTPUT - NO contact closed

### 7. WIRING DIAGRAM

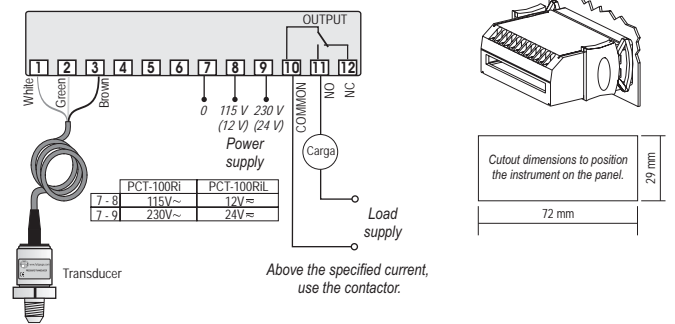

### SCHEMATIC FOR TRANSDUCER

Brown: 5Vdc  
Green: Ground  
White: Output



### IMPORTANT

Attention on transducer installation, do not turn on the terminals on reverse position, it can damage totally the transducer.

According to the chapters of norm IEC 60364:

- 1: Install protector against overvoltage on the power supply.
  - 2: Sensor cables and signal cables of the computer may be joined, but not in the same electric conduit through which the electric input and the activation of the loads run.
  - 3: Install transient suppressor (RC filter) parallel to the load as to increase the product life of the relays.
- For more information, please contact our Technical Support by e-mail: [support@fullgauge.com](mailto:support@fullgauge.com) or by phone +55 51 3475.3308

### Schematic for the connection of supresors to contactors

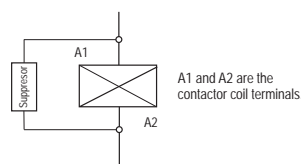

### Schematic for the connection of supresors to direct activation loads



### PROTECTIVE VINYL:

This adhesive vinyl (included inside the packing) protects the instruments against water drippings, as in commercial refrigerators, for example. Do the application after finishing the electrical connections.

Remove the protective paper and apply the vinyl on the entire superior part of the device, folding the flaps as indicated by the arrows.

