



# MT-516RVT *i plus*

## TEMPERATURE CONTROLLER WITH CYCLICAL TIMER AND VOLTAGE MONITOR

Ver.06



MT516RVTI06-04T-10811

### 1. DESCRIPTION

The **MT-516RVT *i plus*** integrates a heating or cooling thermostat with a cyclical timer and a TrueRMS voltage monitor. Through the F13 and F14 functions it is possible to determine the voltage limits that the thermostat output can be active, this way protecting the compressor. Using True RMS<sup>\*</sup> technology the controller is capable of measuring the voltages in a variety of different situations in the electrical grid, thus providing greater precision in the protection of the components of the application. Product complies with UL Inc. (United States and Canada).

\*True RMS: Is the real and effective voltage value which also includes the voltage generated by high frequency noise in the distributing network (harmonic distortion). This is the actual voltage applied to the connected load (example: electric motor, compressor). This method allows the precise voltage measurement for any type of wave form. Other measurement methods give correct value of applied voltage only for perfect sine wave forms.

### 2. APPLICATION

- Milk cooling tanks
- Chambers and counters
- Heat pumps

### 3. TECHNICAL SPECIFICATION

- Electric power supply: 115 or 230Vac ±10% (50/60Hz)
- Control temperature: -50 to 105°C (decimal resolution between -10 and 100 °C)  
-58 to 221 °F
- Maximum current : 8(3)A/250Vac 1/4HP (each output)
- Dimensions: 71 x 28 x 71mm
- Operating temperature: 0 to 50°C / 32 to 122°F
- Operating humidity: 10 to 90% RH (without condensation)

### 4. CONFIGURATIONS

#### 4.1 - Control temperature adjust (SETPOINT)

- Press **SET** for two seconds until **SE E** appears on the display.
- The actual control temperature will appear.
- Use the **▼** and **▲** keys to change the value and press **SET** when ready.

#### 4.2 - Parameters table

Fun	Description	Minimum	Maximum	Default
F01	Access code: 123 (one hundred and twenty three)	-	-	-
F02	Temperature indication offset <sup>(1)</sup>	-5.0°C / -9°F	5.0°C / 9°F	0.0°C / 0°F
F03	Thermostat operating mode	0-cooling	1-heating	0-cooling
F04	Minimum setpoint allowed for the end user	-50°C / -58°F	105°C/221°F	4.0°C / 39°F
F05	Maximum setpoint allowed for the end user	-50°C / -58°F	105°C/221°F	5.0°C / 41°F
F06	Control temperature differential (hysteresis)	0.1°C / 1°F	20.0°C / 36°F	1.0°C / 2°F
F07	Delay for turning the compressor on	0 sec.	999 sec.	180 sec.
F08	Cyclical timer's time base	0-sec.	1-min.	1-min.
F09	Cyclical timer's on time	1 sec./min.	999 sec./min.	3 sec./min.
F10	Cyclical timer's off time	1 sec./min.	999 sec./min.	12 sec./min.
F11	Initial state of cyclical timer	0-off	1-on	1-on
F12	Cyclical timer always on when the compressor is on <sup>(2)</sup>	0-no	1-yes	1-yes
F13	Minimum working voltage (protection) <sup>(3)</sup>	90 Volts	280 Volts	195 Volts
F14	Maximum working voltage (protection) <sup>(3)</sup>	90 Volts	280 Volts	260 Volts
F15	Voltage indication offset	-50 Volts	50 Volts	0 Volts
F16	Voltage confirmation delay <sup>(3)</sup>	1 sec.	30 sec.	10 sec.
F17	Display indication mode <sup>(4)</sup>	0	2	0
F18	Equipment address in the RS-485 network	1	247	1

<sup>(1)</sup>F02 - Temperature indication offset

The F02 functions allows for the correction of any changes in the reading, resulting from a change in the sensor or alteration of the length of the cable.

<sup>(2)</sup>F12 - Cyclical timer always on when the compressor is on:

This function works for some applications, as for example, on cooling tanks for milk, where the timer commands the agitator that must remain on while cooling is taking place.

<sup>(3)</sup>F13/F14/F16 - Operation of the voltage monitor

If the value of the voltage exceeds the limits set in F13 and F14 the compressor will be automatically turned off after the time set in function F16 has lapsed.

The led "VOLTS" will slowly blink along with the Indication of the grid voltage on the display.

In the event that the voltage returns to the limits established, the compressor will only be turned on again after the time scheduled in the F16 function has ended.

To deactivate the voltage monitoring, all you have to do is adjust functions F13 and F14 to the same value.

<sup>(4)</sup>F17 - Display indication mode

Function F17 allows you to choose the measurement that will be displayed during normal operation:

- 0** Temperature
- 1** Voltage
- 2** Temperature and voltage

#### 4.3 - Selection of the unit (°C / °F)

In order to define the temperature unit that the instrument will operate, enter the access code "231" in the function **F01**. The indication **Un** will appear. Press **▼** or **▲** to choose between **°C** or **°F** and confirm with **SET**. After selecting the unit the indication **FAC** will appear and the instrument will return to the function **F01**. Whenever the temperature unit is modified, the parameters should be reconfigured, since they will assume the default values.

#### 4.4 - Parameters alteration

- Access function F01 by pressing the **▼** and **▲** keys at the same time for 2 seconds. When the message **FUn** appears release the keys and wait for the **F01** indication.
- Press the **SET** button to access the function and use **▼** and **▲** to enter the code 123. When ready press again the **SET** button to confirm the code and quit the function F01.
- Select other functions by pressing **▼** or **▲**. To access the desired function press the **SET** key quickly.
- Adjust the function's new value with the **▼** and **▲** keys and press **SET** to save and return to the functions menu.
- To exit the functions menu and return to normal operation press the **SET** button until the message **--** appears on the display.

### 5. FUNCTIONS WITH FACILITATED ACCESS

#### 5.1 - Minimum and maximum logs

Press and release the **SET** key quickly. The indication **U** will appear followed by the minimum and maximum logged voltages. Shortly after the last voltage the **LE** indication will be shown and the minimum and maximum temperatures will be displayed.

Note: to reset the minimum and maximum logs just keep pressing the **SET** key during the visualization of the logs. The message **SE E** will appear indicating the successful operation.

#### 5.2 - Cyclical timer On/Off status change

To change the output of the cyclical timer from "on" to "off" or vice versa just press the **▼** key until the **-** appears on the display.

#### 5.3 - Cyclical time visualization

To visualize the current status (on/off) time that has already lapsed on the cyclical timer press **▲** quickly.

#### 5.4 - Temperature, voltage and frequency visualization

To consult the voltage and frequency of the electrical grid when the controller is configured to display the temperature just push the **▼** key quickly. The current voltage value will be displayed followed by the frequency indication **F** and it's value.

To visualize the temperature while the controller is displaying the voltage press the **▼** key like explained above.

### 6. SIGNALLING

THERM - Thermostat output active ;

VOLTS (always on) - Indicates the voltage visualization;

VOLTS (blinking slowly) - Indicates voltage in out range condition;

VOLTS (blinking quickly) - Indicates an error on the voltage measurement;

TIMER - Cyclical timer output active.

**E F F** - Sensor disconnected or temperature out of the specified range.

If the instrument shows **P P P** on the display it means that a parameter is out of acceptable range and it must be corrected.

### 7. WIRING DIAGRAM

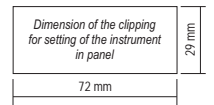
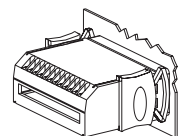
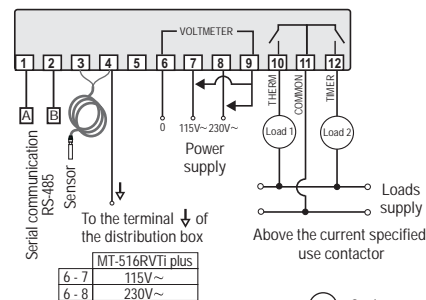

**VOLTMETER:**  
Connect the borne 9 to borne 7, when the instrument is supplied in 115Vac or borne 9 to borne 8, when the instrument is supplied in 230Vac.

- Load1** - Cooler  
- Heater  
- Contact  
- Solenoid
- Load2** - Belt  
- Agitator  
- Water 'pump  
- Contact

Note: The length of the cable for the sensor may be increased by the user up to 200 meters, using PP 2 x 24 AWG cable. For immersion in water use thermometric well.

## Integrating Controllers, RS-485 Serial Interface and Computer

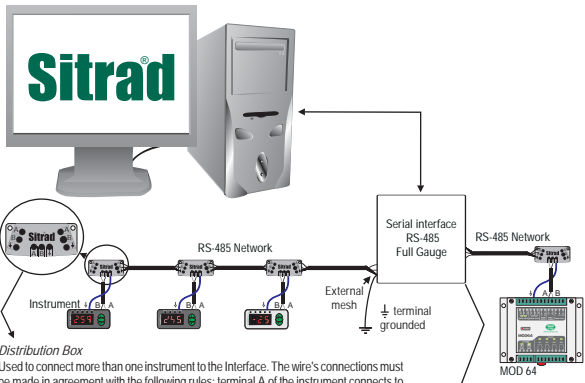

**Distribution Box**  
Used to connect more than one instrument to the Interface. The wire's connections must be made in agreement with the following rules: terminal A of the instrument connects to the terminal A of the distribution box, that must be connected with the terminal A of the Interface. Repeat the action for terminals B and  $\downarrow$ , being  $\downarrow$  the cable shield. The terminal  $\downarrow$  of distribution box must be connected to the respective terminals  $\downarrow$  of each instrument.

**RS-485 Serial Interface**  
Device used to establish the connection Full Gauge Controls' instruments with the Sitrad'

### IMPORTANT

According to the chapters from the IEC60364 standard:

- 1: Install protectors against over voltage on power supply
  - 2: Sensor cables and computer signals can be together, however not at the same place where power supply and load wires pass for
  - 3: Install suppressor of transient in parallel to loads to increase the usefull life of the relays
- For more information contact our application eng. department through e-mail [support@fullgauge.com](mailto:support@fullgauge.com) or dial +55 51 3475.3308.

Wiring diagram of suppressors in contactors

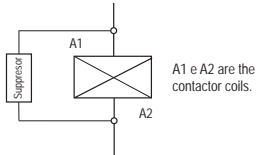

Wiring diagram of suppressor for direct drive

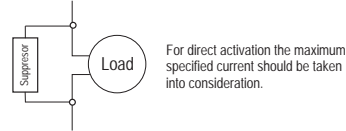

### PROTECTIVE VINYL:

This adhesive vinyl (included inside the packing) protects the instruments against water drippings, as in commercial refrigerators, for example. Do the application after finishing the electrical connections.

Remove the protective paper and apply the vinyl on the entire superior part of the device, folding the flaps as indicated by the arrows.

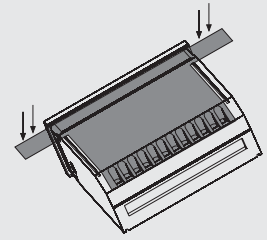

© Copyright 2006 • Full Gauge Controls® • All rights reserved.