



MONIVOLT

UNDER AND OVERVOLTAGE TRUE RMS PROTECTOR

Ver.02



MONIVOLT02-01T-11211

1. DESCRIPTION

The **MONIVOLT** is a single phase protector intended for electrical device either in a home, commercial or industrial environment. **MONIVOLT** uses the True RMS measurement method for monitoring the voltage and protecting single-phase load against under and overvoltage. In addition, the **MONIVOLT** has an automatic timer that in the event of falling or variations of electricity below or above the limits established, will wait 3 minutes after the return to normal conditions to turn on the equipment protected. This function ensures the equipment protection (e.g. : compressor) that needing time to stop completely.

*True RMS: Is the real and effective voltage value which also includes the voltage generated by high frequency noise in the distributing network (harmonic distortion). This is the actual voltage applied to the connected load (example: electric motor, compressor). This method allows the precise voltage measurement for any type of wave form. Other measurement methods give correct value of applied voltage only for perfect sine wave forms.

2. APPLICATION

- Single phase electrical device protection

3. TECHNICAL SPECIFICATIONS

- Power Supply: 80 - 290Vac (50/60Hz)
- Load current: 16(8)A/250Vac 1HP
- Dimensions : 81 x 30 x 63mm
- Operating temperature: 0 to 50°C
- Operating humidity: 10 to 90% RH (without condensation)

4. CONFIGURATION

4.1 - Adjust the operating voltage selector key according to the nominal voltage of the equipment to be protected:

4.1.1 - In regions where the nominal voltage is between 110 and 127Vac, place the key to selection of voltage for 110-127V:



4.1.2 - In regions where the nominal voltage is between 220 and 254Vac, place the key to selection of voltage for 220-254V:



4.2 - Adjust the selection keys with the minimum and maximum voltages accepted:

Operating voltage key: 115Vac

Keys 1 2 3	Minimum Voltage (Vac)	Maximum Voltage (Vac)
■ ■ ■	109	120
■ ■ □	103	126
■ □ ■	97	132
□ ■ ■	92	138
■ ■ □	120	133
■ □ □	114	139
□ □ ■	108	146
□ □ □	101	152

Operating voltage key: 230Vac

Keys 1 2 3	Minimum Voltage (Vac)	Maximum Voltage (Vac)
■ ■ ■	209	231
■ ■ □	198	242
■ □ ■	187	253
□ ■ ■	176	264
■ ■ □	228	252
■ □ □	216	264
□ □ ■	204	276
□ □ □	192	288

Example of application:

For a refrigerator powered by 220V intended to have the power supply voltage controlled between 198 and 242V (220±10%), set the selection keys 1 and 2 up (↑↑) and key 3 down (↓).

The final keys setting should be: ■ ■ □

In this example when the voltage is below of 198 or above 242V, the equipment is turned off and only turn on again after the return of power to the normal conditions.

5. SIGNALLING

POWER LED ON: Equipment powered ON and operating correctly

POWER LED flashing: Voltage measurement error

VLOW LED ON: Low voltage

VHIGH LED ON: High voltage

DELAY LED ON: Timer inside the 3-minutes delay before turning the output ON again.

6. WIRING DIAGRAM

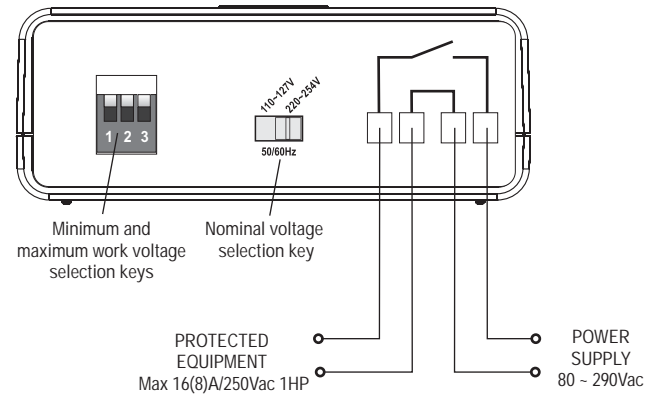

7. TECHNICAL SUPPORT

For more information contact our application eng. department through e-mail support@fullgauge.com or dial +55 51 3475.3308.

© Copyright 2006 • Full Gauge Controls® • All rights reserved.